

MILITARY SPECIFICATION

CV 7375.

SEMICONDUCTOR DEVICE DIODE

Description:- This specification covers the detail requirements for Silicon Broadband Low Level Detector Crystals for Q Band, and is in accordance with specification K1007 Issue 3, except as otherwise stated.

Mechanical Dimensions and Outlines:- See Fig. 1. Page 11.
Construction, Coaxial Shielded.

Connections:- The Pin is the Cathode.

Absolute Maximum Ratings:-

RATING	Tamb	Tstg	SHOCK	VIBRATION
UNIT	°C	°C	g	g
MIN.	-55	-55	-	-
MAX.	+70	+70	500	10

Note : A. Prototype. VX,4189

(204679)

REQUIREMENTS

Marking The device shall be marked as K1007 Section B.

QUALITY ASSURANCE PROVISIONS

Destructive Tests The tests listed in Table 2. Group B Inspection Sub-Groups 2, 3 and 4 and Table 3, Group C Inspection Sub-Group 1 are considered destructive.

PREPARATION FOR DELIVERY

Packaging for Delivery The device shall be packed according to K1007 Issue 3 Section A, 1.2(c). A.I.S. Carton Size 6.

JOINT SERVICES CATALOGUE NUMBER

CV.7375 = 5960-99-037-

This specification has been prepared by, and the Qualification Approval Authority is:-

Ministry of Aviation, Royal Aircraft Establishment, Farnborough, Hants,
England.

1st October, 1963.

Page 3 of 11 Pages

CV7375

TABLE 1. GROUP A INSPECTION

Examination or Test	TEST CONDITIONS	AQL %	Insp. Level	Symbol	LIMITS		Units
					Min.	Max.	
	K1007/ NATO Ref.						
<u>SUB-GROUP 1</u> Visual and Mechanical Inspection	5.1 Excluding Physical Dimensions	0.65	II				
<u>SUB-GROUP 2</u> Figure of Merit	Forward Bias $50 \mu\text{A} \pm 1 \text{ uA}$ $f = 31.6 \text{ Gc/s} \pm 0.1\%$ <u>NOTES 1, 2 and 3</u>		100%	M	20	-	-
Reverse Current	$V_R = -0.5 \text{ Volt}$		100%	I_R	-	25	μA

TABLE 1. GROUP A INSPECTION (Contd.)

Examination or Test	TEST CONDITIONS	AQL	Insp.	Symbol	LIMITS		Units
					Min.	Max.	
Voltage of Standing Wave Ratio	K1007/ NATO Ref. TEST CONDITIONS Power Level 5 uW Max. Forward Bias 50 μ A \pm 1 μ A NOTE 3 Relative to 1/61 mho f(1) = 26.1 Gc/s \pm 0.1% f(2) = 31.6 Gc/s \pm 0.1% f(3) = 40.0 Gc/s \pm 0.1%		100%				
			100%	0.2	-		
			100%	0.2	-		
Video Resistance	8.B.4.1		I	R _V	600	950	OHMS
Forward Current	Vf = 0.5 Volt	2.5	I	I _F	2	-	mA
SUB-GROUPS 3 and 4 OMITTED							

TABLE 2 GROUP B INSPECTION

Examination or Test	TEST CONDITIONS		AQL %	Insp. Level	SYMBO	LIMITS		Units
	K1007/ NATO Ref.	SPECIFIC CONDITIONS				Min.	Max.	
<u>SUB-GROUP 1</u> Physical Dimensions	5.1	To Drawing Fig.1 Page 11	6.5	IA				
<u>SUB-GROUP 2</u> Temperature Cycling	5.5	T = -55°C to + 100°C 5 cycles	4.0	IA				
Moisture Resistance	5.3.1.2	Duration 7 Days Temperature = +35°C ± 20°C						
<u>SUB-GROUP 3</u> Vibration Fatigue	5.15.1	Non-operating Max. Peak Acceleration = 10g	4.0	IA				
<u>SUB-GROUP 4</u> Tension Test	5.11	Weight 2 lb. Duration 10 Secs.	6.5	IA				
<u>SUB-GROUP 5 OMITTED</u>								
<u>SUB-GROUP 6 OMITTED</u>								
<u>SUB-GROUP 7</u> High and low temperature (Non-operating)	6.2							
High Temperature	6.2.1	T Stg. = 70°C Duration 150 hrs						
Low Temperature	6.2.2	T Stg. = -55°C Duration 150 hrs						

TABLE 2 GROUP B INSPECTION (Contd.)

Examination or Test	K1007/ NATO Ref.	TEST CONDITIONS		AQL %	Insp. Level	Symbol	LIMITS		Units
		SPECIFIC CONDITIONS					Min.	Max.	
<u>SUB-GROUP 8 OMITTED</u>									
<u>END POINTS FOR</u> <u>SUB-GROUPS 2, 3, 4 &</u> <u>7</u>									
Reverse Current		As in Group A Inspection Sub-Group 2		6.5		I _R	-	40	µA
Figure of Merit		As in Group A Inspection Sub-Group 2		6.5		M	15	-	

TABLE 3 GROUP C INSPECTION

Examination or Test	TEST CONDITIONS		AQL %	Insp. Level	Symbol	LIMITS		Units
	K1007/ NATO•Ref.	SPECIFIC CONDITIONS				Min.	Max.	
<p><u>SUB-GROUP 1</u> Burnout</p> <p><u>END POINT FOR SUB</u> <u>GROUP 1</u> Change in Figure of Merit</p>		<p>R.F. Peak Power = 20 mW min. $f = 35 \text{ Gc/s} \pm 1\%$ $t_p = 0.25 \pm 0.05 \text{ u Sec.}$ P.r.f. 1000 \pm 100 p.p.s Duration = 1 hour</p> <p>As in Group A Inspection Sub Group 2</p>	6.5	I _B	ΔM	-40	+60	%

TABLE 3 GROUP C INSPECTION (Contd.)

Examination or Test	TEST CONDITIONS		AQL %	Insp. Level	Symbol	LIMITS		Units
	K1007/ NATO Ref.	SPECIFIC CONDITIONS				Min.	Max.	
<u>SUB-GROUP 2</u>								
Shock	5.17	Maximum Acceleration = 500g	6.5	QA				
<u>END POINTS FOR SUB GROUP 2</u>								
Reverse Current	-	As in Group A Inspection Sub Group 2			I _R	-	40	μA
Figure of Merit	-	As in Group A Inspection Sub Group 2			M	15	-	-

NOTES

1. The valves shall be tested in a holder matched to 61 ohms.
2. The figure of merit of biased detectors shall be calculated from the results of comparison measurements of the tangential sensitivities of the biased detectors and unbiased detectors in the same approved apparatus. The figure of merit of the unbiased detector is to be taken as the product of current sensitivity expressed in microamps per microwatt, and the square root of video resistance in ohms.

The current sensitivity is defined as the d.c. open-circuit voltage (mV/ μ W) developed across the valve at an input level between 1 and 5 μ W c.w. divided by the video resistance (ohms). The open circuit voltage may be obtained by a backing off method, using a variable battery supply of low impedance which is adjusted to give zero current through the valve.
3. The bias current shall be obtained from a supply having a minimum source resistance of 50 K .

FIG. 1

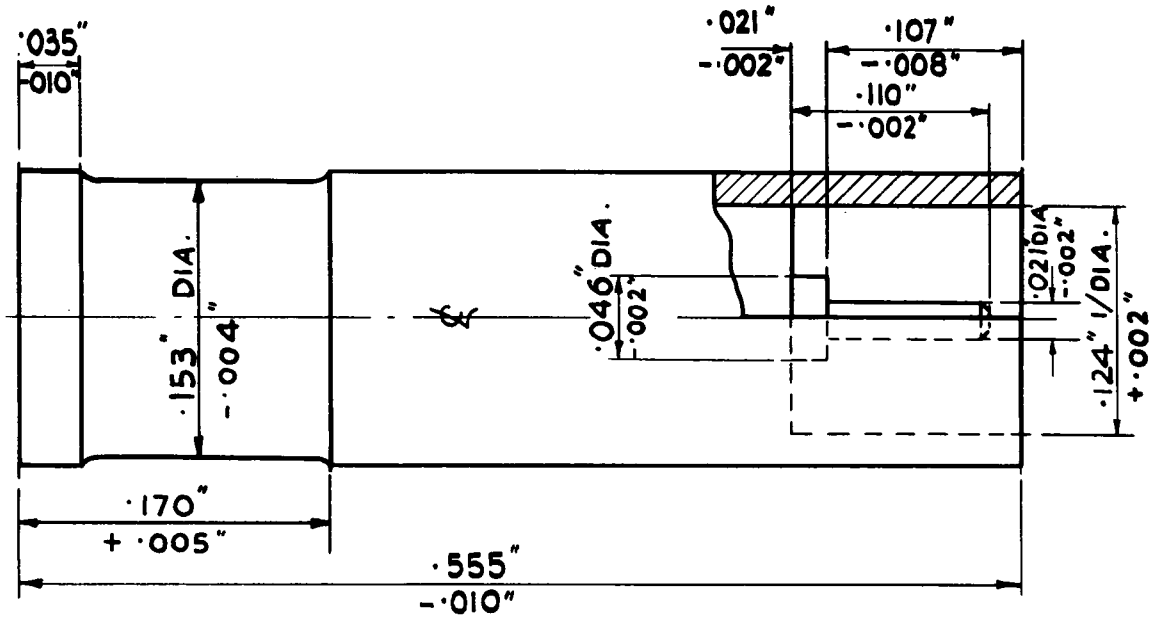

SCALE = 10x FULL SIZE.

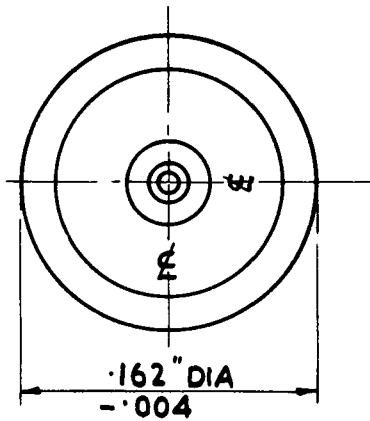

VIEW ARROW 'R'

NOTE :- THIS CRYSTAL VALVE
WILL FIT SAME HOLDER AS
IN 53.



ACTUAL SIZE

